



**बैंक नोट पेपर मिल इण्डिया प्रा. लिमिटेड**  
**BANK NOTE PAPER MILL INDIA PVT LIMITED**  
JV of SPMCIL - A Govt. of India Enterprises & BRBNMPL - A Subsidiary of RBI

Email: [bhoodhar@bnpmindia.com](mailto:bhoodhar@bnpmindia.com)

Tel: 0821-2401-174

Limited tender Enquiry No: BNPM/LTE/ slitter knife /256/2018-19

Start Date: 02.07.2018

END Date: 06.07.2018

Extended up to:10.09.2018

**1. Scope of supply:**

Supply of "sheeter machine knife".

**2. Terms & Conditions:**

S. No.	Particulars	Quantity
1.	Payment Terms	100% on receipt and acceptance of goods by the consignee at destination and on production of all required documents by the supplier. <b><u>NEFT/RTGS details shall be furnished along with invoice.</u></b>
2.	Price	Price should be inclusive of all taxes & duties.
3.	Freight	Shall be included in quoted price
4.	Packing & Forwarding	Shall be included in quoted price
5.	Delivery Terms	DAP, Bank Note Paper Mill India Private Limited, Mysore
6.	Warranty Period	.....(Please specify)
7.	Warranty Certificate	Applicable/ Not Applicable
8.	Delivery Period	.....(Please specify)
9.	Material to be delivered at	Engineering Stores Bank Note Paper Mill India Private Limited Note Mudran Nagar Mysore 570 003

Remarks: Quotation should send by mail to [bhoodhar@bnpmindia.com](mailto:bhoodhar@bnpmindia.com).



बैंक नोट पेपर मिल इण्डिया प्रा. लिमिटेड

BANK NOTE PAPER MILL INDIA PVT LIMITED

JV of SPMCIL - A Govt. of India Enterprises & BRBNMPL - A Subsidiary of RBI

Email: [bhoodhar@bnpmindia.com](mailto:bhoodhar@bnpmindia.com)

Tel: 0821-2401-174

Limited tender Enquiry No: BNPM/LTE/ slitter knife /256/2018-19

Price Bid Format:

S. No.	Description	Qty. A	UOM B	Unit rate C	GST @.....% D	Total E=C+D	Grand Total F=E*A
1	<b>Slitter bottom Knife -Sheeter As per attached specification</b>	6	NOS				
2	<b>Slitter top Knife - Sheeter As per attached specification</b>	6	NOS				
						Grand Total	
Grand Total In Words:							

We hereby confirm that

1. We accept all terms & conditions mentioned in the enquiry.
2. Price quoted is inclusive of all taxes, P&F, freight, insurance etc. on DAP, BNPM, Mysore basis.
3. HSN Code:

Signature of bidder:.....

Name of the Firm:.....

Seal of the firm: .....

GST No: .....

*Handwritten signature*

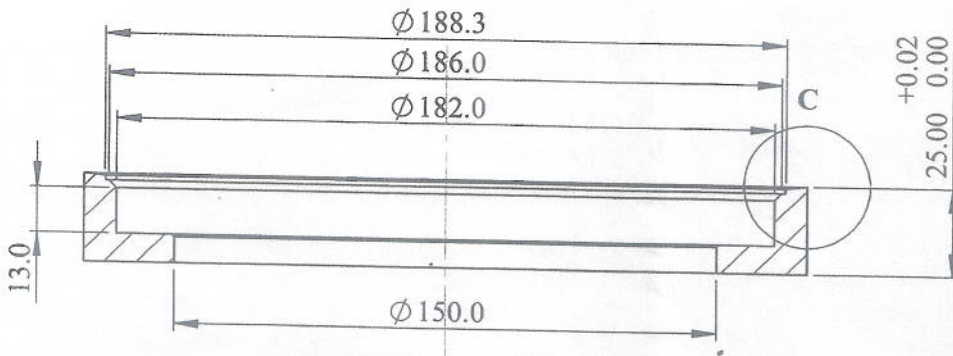

SECTION B-B  
 SCALE 1 : 2

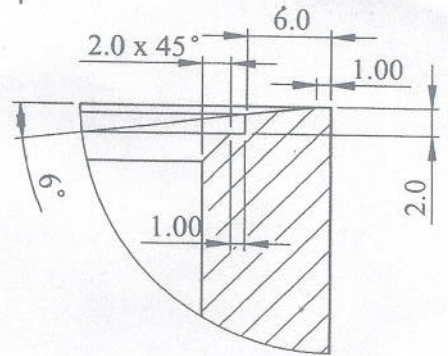
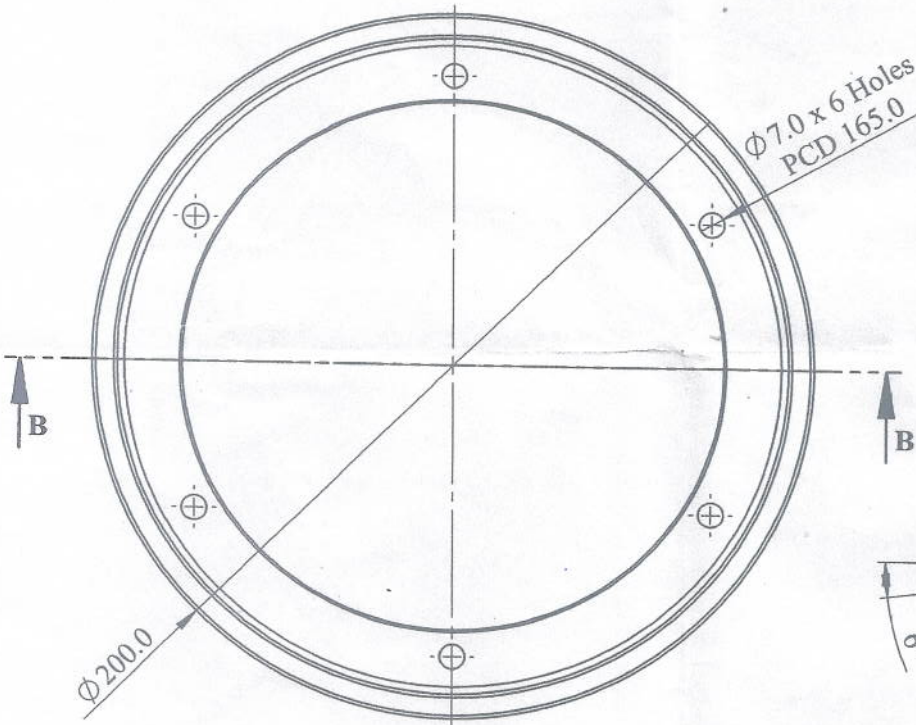

DETAIL C  
 SCALE 2 : 1

Note : Unspecified linear tolerance is  $\pm 0.05$   
 Angular tolerance is  $\pm 0^{\circ}30'$

UNLESS OTHERWISE SPECIFIED DIMENSIONS ARE IN MILLIMETERS SURFACE FINISH: TOLERANCES: LINEAR: ANGULAR:				DEBUR AND BREAK SHARP EDGES		DO NOT SCALE DRAWING		REVISION	
						BANK NOTE PAPER MILL INDIA PRIVATE LIMITED Mysore / MYSORE			
DRAWN		SIGNATURE		DATE		TITLE			
CHK'D		SIGNATURE		DATE		06 JUN 2018		BNPM	
APPV'D		SIGNATURE		DATE		262		Slitting Knife Bottom	
MFG		SIGNATURE		DATE					
Q.A		SIGNATURE		DATE					
				MATERIAL: SS - ASP23 (Assumed)		DWG NO.		A4	
				WEIGHT:		SCALE:1:1		SHEET 1 OF 1	

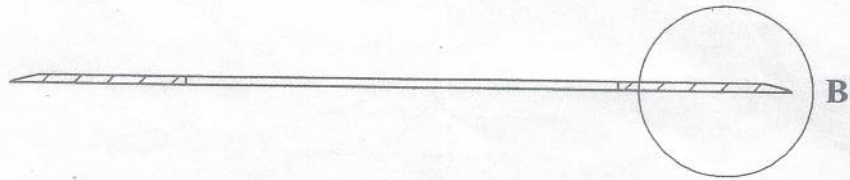

SECTION A-A  
SCALE 1 : 2

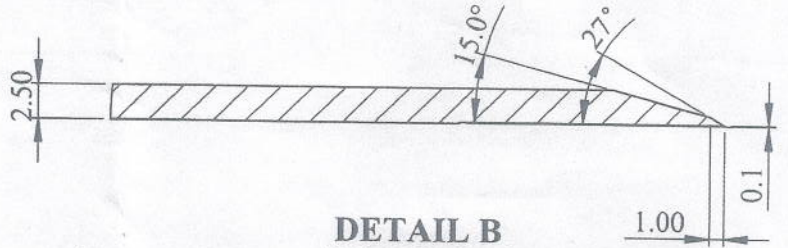

DETAIL B  
SCALE 2 : 1

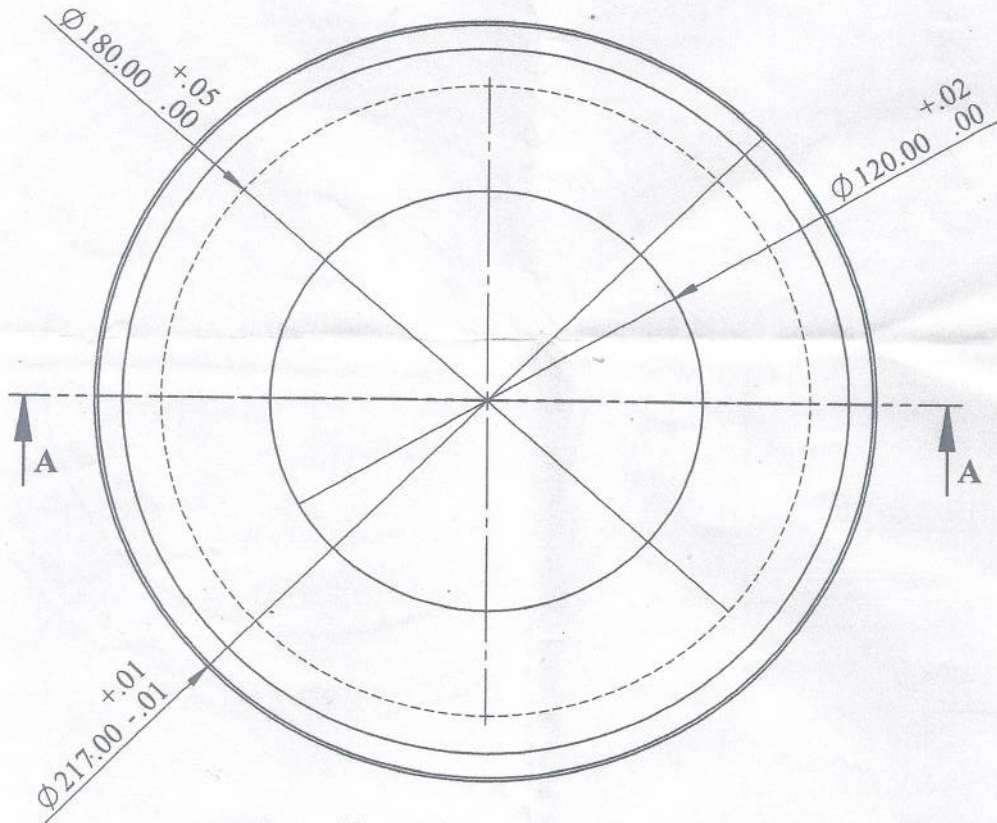

Note : Unspecified linear tolerance is  $\pm 0.05$   
Angular tolerance is  $\pm 0^{\circ}30'$

UNLESS OTHERWISE SPECIFIED: DIMENSIONS ARE IN MILLIMETERS SURFACE FINISH: TOLERANCES: LINEAR: ANGULAR:			FINISH:		DEBUR AND BREAK SHARP EDGES		DO NOT SCALE DRAWING बैंक नोट पेपर मिल इंडिया प्राइवेट लिमिटेड Bank Note Paper Mill India Pvt. Ltd. मैसूर / MYSORE		REVISION		
DRAWN: <i>Shouvik</i>			SIGNATURE: <i>[Signature]</i>		DATE: 12/4/18		TITLE: 06 JUN 2018		<b>BNPM</b> आवक सं/Inward No. 261 <b>Slitting Knife Top</b>		
CHK'D: <i>RADHAKRISHN</i>			SIGNATURE: <i>[Signature]</i>		DATE: 12/4/18		DWG NO.				
APP'VD:			SIGNATURE: <i>[Signature]</i>		DATE:		MATERIAL: SS-ASP23		SCALE: 1:1		
MFG:			SIGNATURE:		DATE:		WEIGHT:		SHEET 1 OF 1		
Q.A:			SIGNATURE:		DATE:						

*[Handwritten Signature]*